



SCPRO 4A BL

User Manual
Version 1.0



SAFETY INSTRUCTIONS

1. Read this manual carefully.
2. Follow all instructions and warnings.
3. Only use accessories specified by WORK PRO.
4. Follow the safety instructions of your country.
5. Be careful with sound levels.

SYMBOLS

The following symbols are used in this document:



This symbol indicates a potential risk of harm to a person or damage to the product. You can also notify the user of the instructions that must be followed strictly to ensure the installation or safe operation of the product.



This symbol notifies the user about the instructions that must be followed strictly to ensure the correct installation or operation of the product.



This symbol notifies the user about additional information or optional instructions.

WELCOME TO WORK PRO

Thank you for choosing the WORK PRO SPCRO 4A BL system.

This document contains essential information on the use of the system. Read this document carefully to become familiar with the system.

Please check the WORK PRO website regularly to download the latest version of the document and software updates: <https://www.workpro.es/>

CONTENT

1. INTRODUCTION.....	3
2. Components of the BlueLine Digital MKII System	4
3. RECEIVERS.....	4
3.1. Audio extracting methods.....	5
3.1.1. DUAL.....	5
3.1.2. SINGLE	5
3.1.3. MONO.....	6
3.1.4. INVERT OUT.....	7
4. SCPRO 4A BL.....	8
4.1. Características.....	9
4.2. Description of the device	10
4.2.1. Puerto LAN	10
4.2.2. REMOTE.....	11
4.2.3. GPIOs	11
4.2.4. Analogic audio output	12
4.2.5. Amplified audio output	12
4.2.6. Main supply input.....	13
4.3. Device Setup	14
4.4. Accessories.....	15

1. INTRODUCTION

The devices of the BlueLine Digital MKII series allow the streaming of audio over IP through Ethernet, complying with the TCP / IP protocol stack. Using the BlueLine Digital MKII system it is possible to perform from a simple point-to-point audio transmission to a complex multi-channel system with alarm control and management.

BlueLine Digital MKII can make use of the existing physical network infrastructure in the installation, due to its low bandwidth consumption. On the other hand, it is compatible with commonly used low or high impedance amplification systems.

Thanks to the modular design of the system, BlueLine Digital MKII adapts perfectly to the features of each installation, being able to expand the system in the future if the characteristics of the installation require it.

Features:

- Management of audio streamers and receivers.
- Different types of coding (PCM, MP3).
- Different audio extraction modes (Dual, Single, Mono).
- Control by OSC commands.
- Control by GPIO.
- Complement with the family of Light Mouse devices.
- Real-time system monitoring.
- Configuration by software.
- External power supply or PoE.

2. Components of the BlueLine Digital MKII System

In this chapter you will find information about the different devices that make up the BlueLine Digital MKII system.

The BlueLine Digital MKII system has four kinds of devices:

STREAMERS	BLS2 LITE MKII	One stereo channel sender
	BLS2 SD MKII	One stereo channel sender with SD player
RECEIVERS	BLR2 LITE MKII	One stereo channel receiver
	BLR2 MKII	One stereo channel receiver with 2xGPIs/2xGPOs
	BLR2 A plus MKII	One stereo channel receiver with 2xGPIs/2xGPOs and low impedance amplifier
PAGING	SPS 8	Paging station
WALLMOUNT CONTROLLERS	BLC 1	Wallmount controller for local receiver
	WNC 1	Wallmount controller through the network
	WAC 7	Customizable wallmount controller

Note: The BlueLine Digital MKII series is compatible with the previous series of devices, so you can include devices of both series in your installation.

3. RECEIVERS

The BlueLine MKII receivers are devices that are responsible for extracting one stereo audio channel from the network. There are several types of receivers:

BLR2 LITE MKII: Receiver of one stereo channel.

BLR2 MKII: Receiver of one stereo channel with 2GPIs / 2GPOs.

BLR2 A PLUS MKII: Receiver of one stereo channel with amplification module and 2xGPIs / 2xGPOs.

BlueLine receivers do not consume bandwidth by audio transmission. Its consumption is associated with UDP / OSC state packets and OSC control packets. This consumption will be disregarded, since it is minimal and it will depend on each specific use.

3.1. Audio extracting methods

It is important to emphasize that each audio receiver is only capable of extracting one stereo audio channel from the network. The extraction of this channel can be done in different ways, that can be select in the configuration interface of WorkCAD3 Configurator.

3.1.1. DUAL

Stereo extraction mode. Each input is assigned to its output.

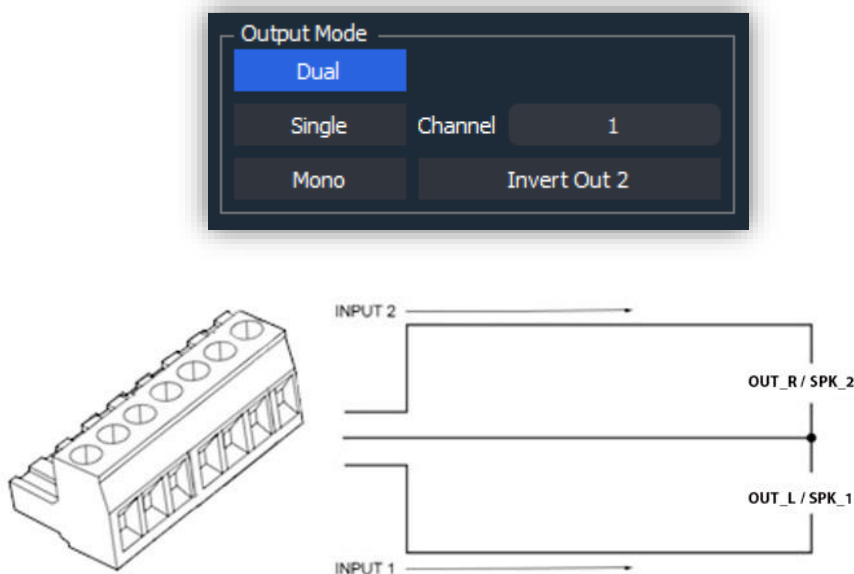

3.1.2. SINGLE

Individual extraction mode. Of the two parts that one stereo channel is conformed (1-L or 2-R), we choose one of them, to extract it by both outputs of the receiver. In this example we select 1-

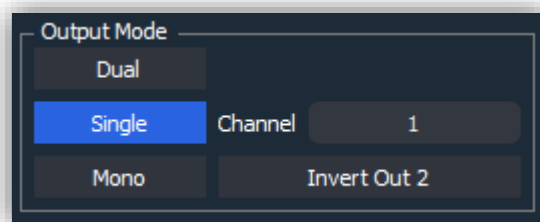

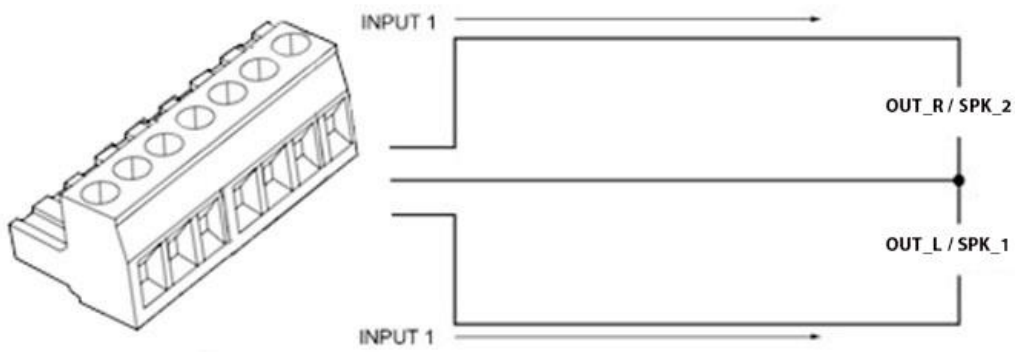

3.1.3. MONO

Mono extraction mode. The two input channels (1-L and 2-R), are summed to extract them by both outputs of the receiver.

6 dB are subtracted from each output to compensate for the electrical sum of two input channels.

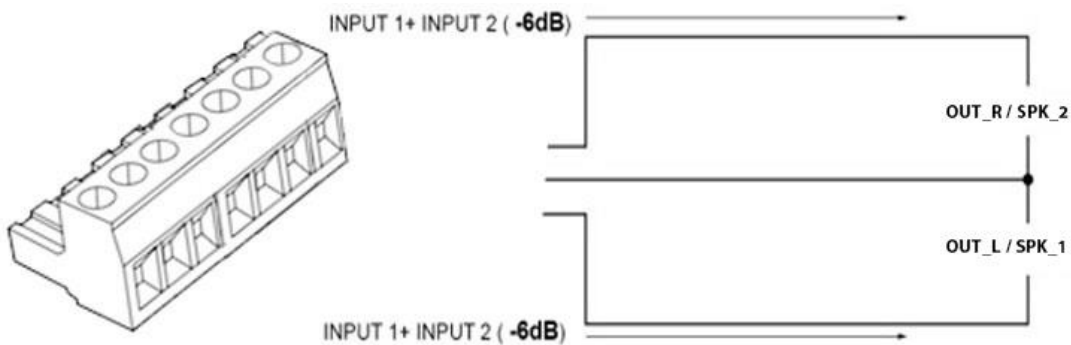
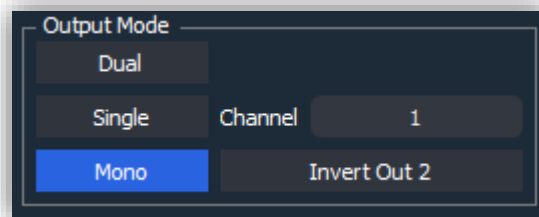

3.1.4. INVERT OUT

Inversion of the polarity for output 2, in order to create a balanced output or Bridge I the case of amplified output. This option is only available for SINGLE and MONO modes. In this case, we select MONO mode

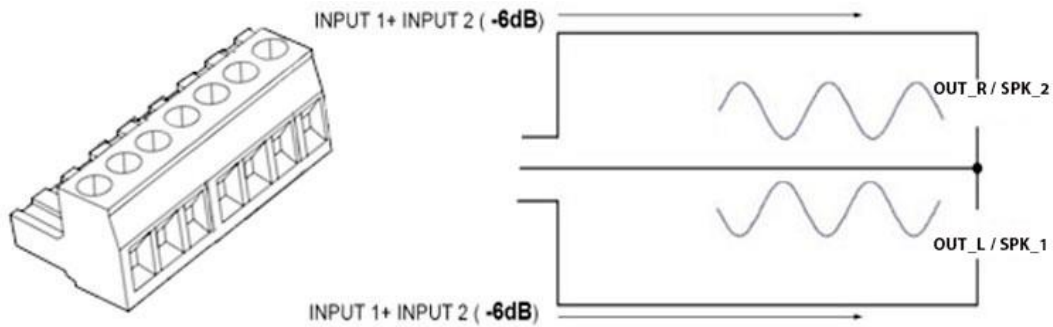
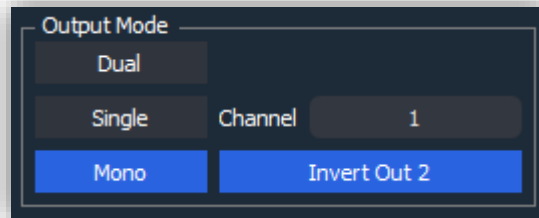

4. SCPRO 4A BL

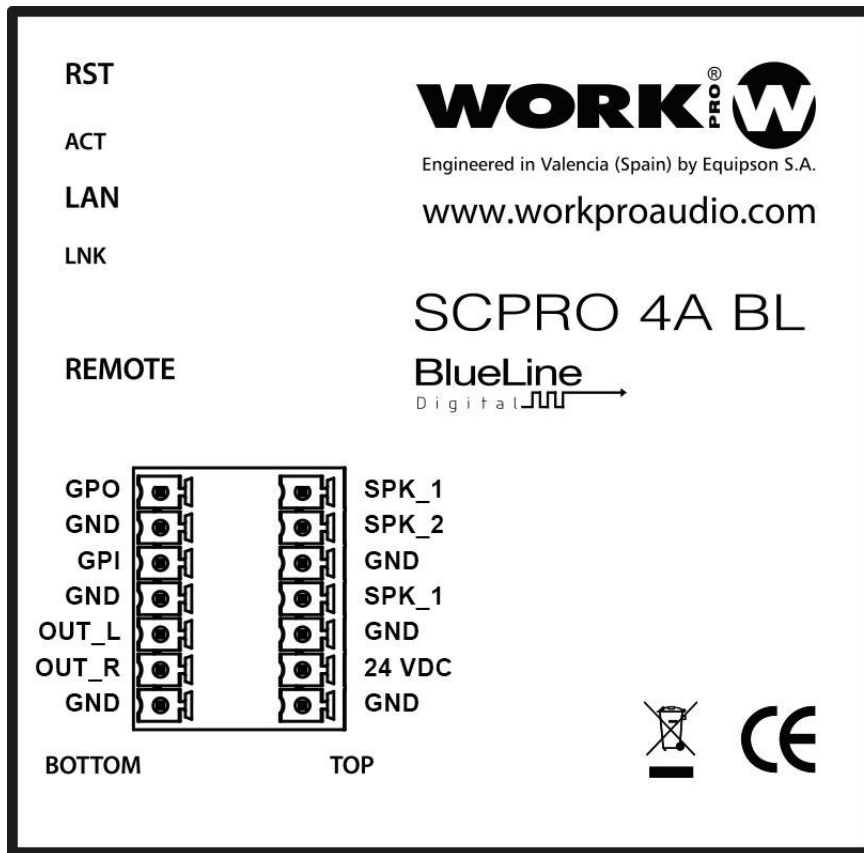

SCPRO 4A BL is a stereo one channel audio over IP receiver with included amplifier. With it you can extract one of the channels emitted by the BlueLine Digital MKII transmitters.

Furthermore, SCPRO 4A BL includes 1x GPI (pull-up) and 1x GPO (open collector). The device can be powered by either PoE or an external power supply.



It must be emphasized that a receiver cannot mix or add channels from different streamers

4.1. Características

Analog audio output	
Number of channels	1 stereo channel (unbalanced) or 1 single /mono channel (balanced)
Audio connector	Euroblock, 3 pin 5.08mm
Output sensitivity	-1.15 dBu (640mV _{rms}), balanced

Amplified audio output	
Power output, dual mode (24Vdc)	2x 20W @ 4 Ω
Power output, Bridge mode (24Vdc)	1x 40W @ 8 Ω
Power output, dual mode (PoE)	2x 5W @ 4 Ω
Power output, Bridge mode (PoE)	1x 10W @ 8 Ω
Input sensitivity	0.7 dBu (840mV _{rms})

GPIO	
GPIs	Pull Up resistor, 5 Vdc max.
GPOs	Open collector, 12Vdc máx. 1A máx.

Network	
Connector	RJ-45
Audio over IP	Datagrams BlueLine UDP
Ethernet	100 Base TX

Supply	
External source	12/24 Vdc (Not included)
PoE Class	Class 0 802.3af
Consumption	31.5 W

General	
Protocolo de control	OSC
Audio extraction modes	Stereo/Single/Mono
Connectivity	2 x Euroblock, 7 pin
Control port	RJ-45
Dimensions	91.2mm x 88.5mm x 40.4mm
Weight	240 g

4.2. Description of the device

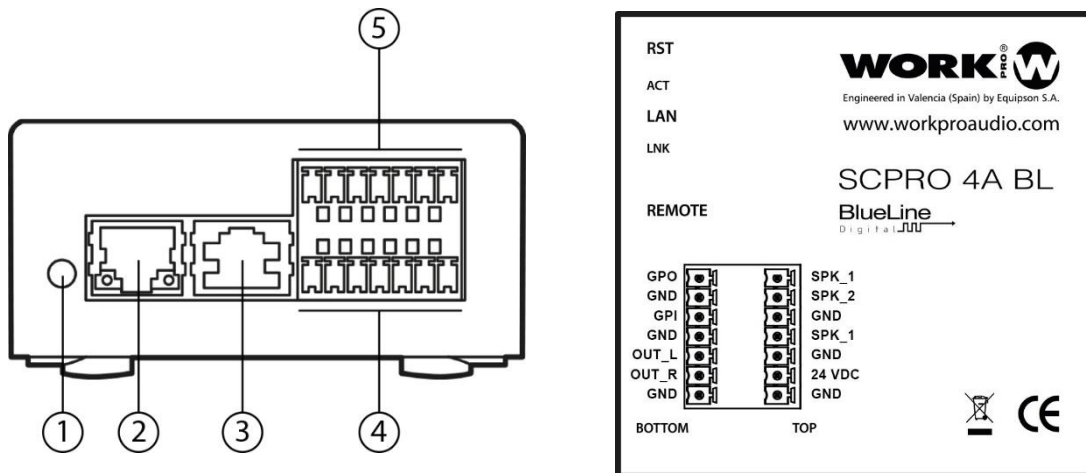

1. **RST.** Take the device to its factory configuration
2. **LAN.** Connection port to local network, RJ45.
3. **REMOTE.** Port for wallmount controller connection BLC 1 (RJ 45).
4. **LOWER Terminal Block (From Left to Right)**
 1. GPO. Open collector, 12Vdc max. 1A max.
 2. GND. Ground connection
 3. GPI. Pull Up resistor, 5 Vdc max
 4. GND. Ground connection
 5. **OUT_L: Left output (line level) for stereo mode or positive por mono balanced.**
 6. GND. Ground connection
 7. **OUT_R: Right output (line level) for stereo mode or negative por mono balanced.**
 - 8.
5. **UPPER Terminal Block (From Left to Right)**
 1. SPK_1: Positive to speaker 1
 2. SPK_2: Positive to speaker 2 (Negative in Bridge mode)
 3. GND. Ground connection
 4. SPK_1: Positive to speaker 1
 5. GND. Ground connection
 6. 24V DC. Positive pin for main supply
 7. GND. Ground connection

4.2.1. Puerto LAN

RJ45 port for LAN connection. Allows PoE power (Class 0 802.3af).

Next to the RJ45 connector you will find two LEDs indicating the status of the device:

LINK (green)	Indicates that the SCPRO 4 BL is connected to the LAN
ACT (orange)	Indicates that packets are being sent or received

4.2.2. REMOTE

This port allows the connection of a BLC 1 wall controller acting as a local command. In this way, it is possible to select the audio source and control the volume.

4.2.3. GPIOs

Inputs and outputs of general purpose. The device includes 1 GPI and 1 GPO.

- **GPI:** Input used to sense logical voltage variations, so that UDP / OSC control commands can be sent when they occur. A typical configuration would be the connection of a push button between GPI and GND, so that when it is pressed or clicked it can send OSC commands, previously programmed through WorkCAD3 Configurator.

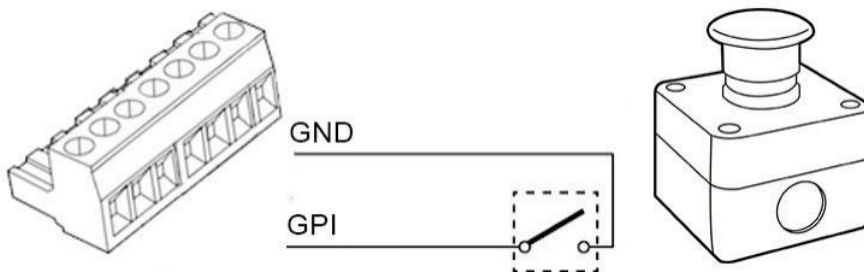

- **GPO:** Output in open collector configuration, which once activated allows current to pass through it. A typical configuration would be the interconnection of a relay coil.

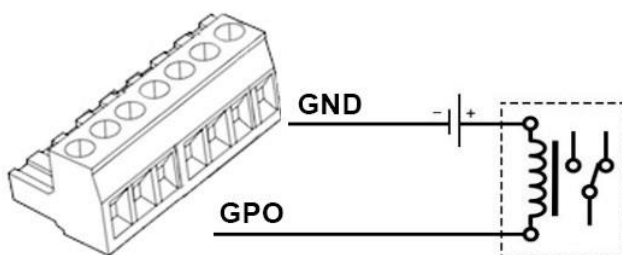

4.2.4. Analog audio output

The device's analog audio output can be balanced or unbalanced depending on the chosen extraction mode. To do this, keep in mind the following connection types:

STEREO UNBALANCED

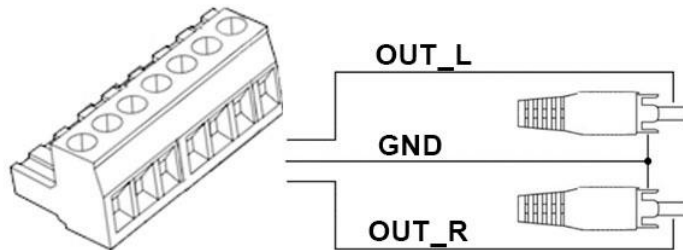

MONO UNBALANCED

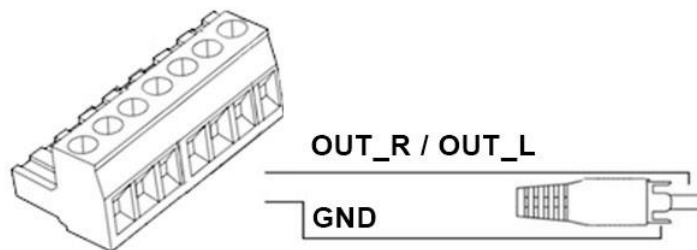

MONO BALANCED

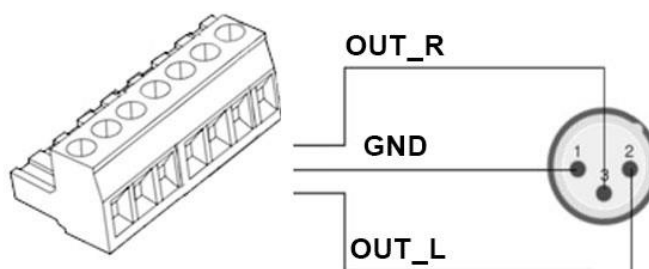

4.2.5. Amplified audio output

The output power of the device will depend on the type of power used. If we want to obtain the maximum power, we must supply it with an external 24Vdc source, below, the different powers offered are detailed according to the power and mode of use:

Amplified audio output	
Power output, dual mode (24Vdc)	2x 15W @ 4 Ω
Power output, Bridge mode (24Vdc)	1x 30W @ 8 Ω
Power output, dual mode (PoE)	2x 5W @ 4 Ω
Power output, Bridge mode (PoE)	1x 10W @ 8 Ω

As can be seen in the chart, we can make a BRIDGE configuration so that the device will deliver all its power in a single output. Remember that the minimum load in this mode of use will be 8 Ω. We will choose the audio extraction mode through WorkCAD3 Configurator.

The different types of connection are detailed below according to the audio extraction mode.

DUAL

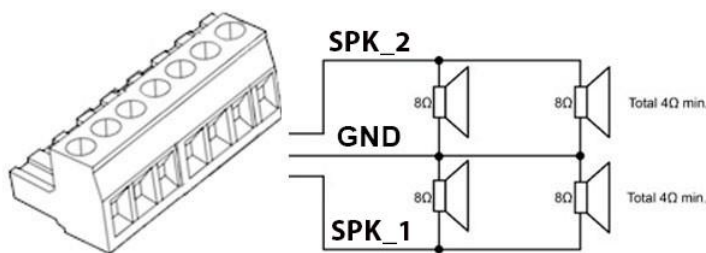

BRIDGE

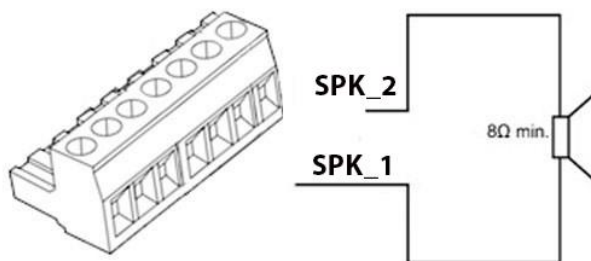

4.2.6. Main supply input

24VDC, 2A power is required to deliver maximum amplifier power.



Check the correct polarity before turning on the power.



The external power supply is not provided with the device.

4.3. Device Setup

The configuration of the device must be done through the WorkCAD3 configurator software, which can be downloaded from our website.

After configuring the device's IP level and updating it if necessary (See WorkCAD3 Configurator manual), proceed with its configuration.

If you click with the left mouse button on the device, the configuration interface will open where the following parameters to be configured appear.

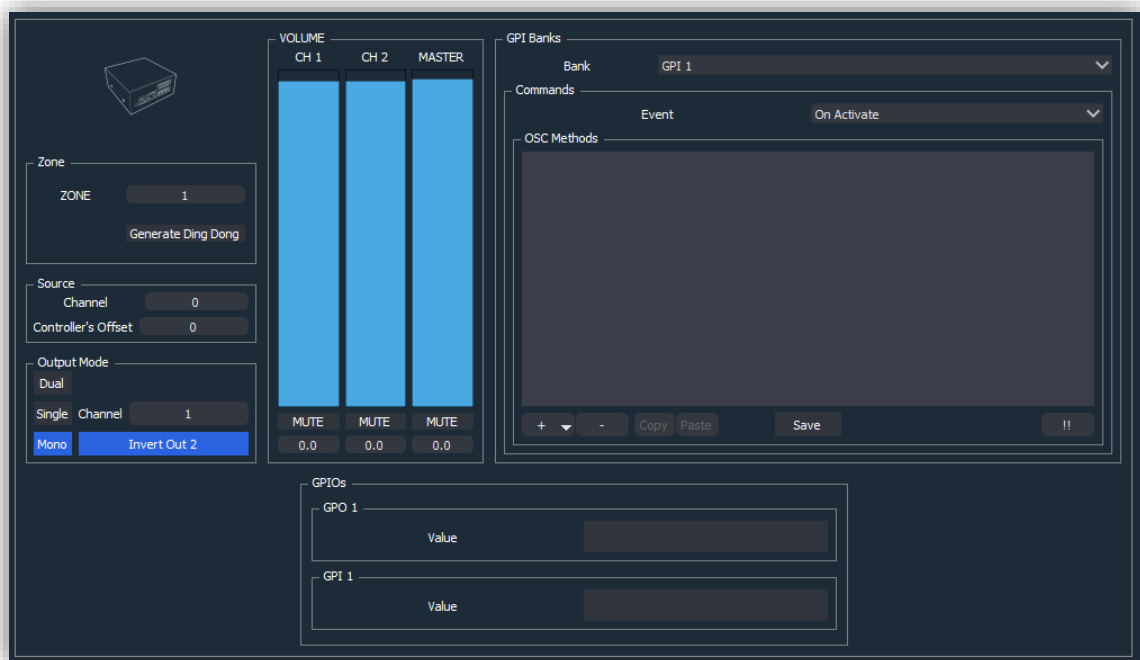

- **Zone:** This field refers to the zone to which the device belongs, in order to receive OSC control commands. By default, all BlueLine receivers come in zone 1.
- **Generate Ding Dong:** Button for the receiver to execute a Ding Dong signal. This is useful to be able to recognize / check the speakers connected to our receiver.
- **Channel:** Stereo audio channel number that we want to extract.
- **Controller's offset:** Field to enter an offset in the wall control (BLC 1 or WNC 1) that controls the device. For example, if we enter "1" in this field, the minimum channel that can be chosen in the wall control will be "1", so that if we have a reserved source in channel "0", the user will not be able to access it.
- **Output mode:**
 - **Dual:** Estereo audio extraction.
 - **Single:** Audio extraction in individual mode.

- **Mono:** Audio extraction in mono mode, adding the two channels and extracting it through both outputs with an attenuation of -6 dB.
- **Channel:** Selection of the channel to extract in individual mode. 1 (L) or 2 (R).
- **Invert Out 2:** Reverse polarity of channel 2 to obtain a Bridge output. Only available in Single and Mono modes.



See section 3.1 (Audio extraction methods) for more details.

- **Volume:** Dedicated field to control the volume and mute channels 1, 2 and Master.
- **Banks:** Field dedicated to programming the GPIs of the device.
 - **Bank:** GPI selection.
 - **Event:** Selection of the command execution mode, according to the high or low level of the signal associated with the GPI. In the case of an On Activate-closed switch. On deactivate-open
 - **OSC Methods:** Field dedicated to the inclusion of UDP / OSC commands.
- **GPIOs:** Field dedicated to reporting the status of GPIOs, on-activated / not on-deactivated. In the case of the GPO you can click on the button to change the status manually

4.4. Accessories

- Magnets for speaker fixation

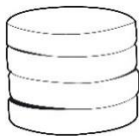



Av. Salar nº 14 Polígono. Ind. L`Alteró. Silla 46460 VALENCIA-SPAIN
Tel: +34 96 121 63 01
www.workpro.es